

Table of Contents

1.	General	2
2.	Initial Check Out	3
3.	Installing the Fuel Flow Transducer	4
4.	Route the Optional warning control line	5
5.	Install the instrument in the panel	5
6.	Route the Fuel Flow Transducer Wires	5
7.	System Checkout	5
8.	Specifications and Limitations	6
9.	Pilot Programmable Modes	7
10.	Drawing 700923	8
11.	Drawing 700922	9
12.	Drawing 700921	10
13.	Drawing 700124 (excerpt from report #103, STC 2586NM)	11
14.	Drawing 700744 (excerpt from report 103, STC 2586NM)	12
15.	Drawing 700920 Installing the Electronics International Fuel Flow Differential Module	13,14

J.P.INSTRUMENTS
PO BOX 7033
HUNTINGTON BEACH CA 92704

EGT-701 with Fuel Flow Option Installation Instructions

1...General:

A complete thorough familiarization and understanding of the system and this manual is necessary before commencing the installation. All work must conform with A.C. 43.13.1A ch. 11 sec. 2, 3, 7. The accuracy of this instrument depends entirely upon the accuracy of the data entered. A periodical checking of the actual fuel onboard will eliminate the accumulation of errors due to evaporation leaks, etc.

Do not use the FXT-201 Flow Transducer on aircraft with a gravity feed system. The standard Fuel Transducer (FXT-201) shipped with the EGT-701(),with Fuel Flow option Fuel Flow instrument is intended to be used on aircraft equipped with fuel pumps. A gravity feed system requires the FXT-231 flow transducer.

Transducer Identification Markings

FXT-201 - Marked "201" on the top of the unit.

FXT-231 - Marked "231" on the top of the unit.

Installation of the EGT-701(),with Fuel Flow option on an aircraft with a fuel return line from the Carburetor requires a FFDM-1 Differential Module to be purchased from Electronics International.

The placard "Do Not Rely on Fuel Flow Instrument to Determine Fuel Levels in Tanks" must be mounted on the aircraft instrument panel near the EGT-701, () with fuel flow option.

If the aircraft is equipped with a primary fuel flow, the following placard must be mounted on the aircraft instrument panel near the EGT-701(),WITH FUEL FLOW OPTION(): "Refer to Original Fuel Flow Instrumentation for Primary Information".

do not obstruct the freedom of travel of arty controls.

2.... Initial Check Out

1. The aircraft owner must read the Warranty before starting the installation. There is information in the Warranty that may alter your decision to install this instrument. If you do **not accept the terms of the Warranty, JPI offers a 30 day money back guarantee.**
2. **If you are not an FAA Certified Aircraft Mechanic familiar with the issues of installing aircraft fuel flow, Do Not attempt to install this instrument.** The installer should use current aircraft standards and practices to install this instrument (refer to AC 43.13).
3. **Check that any necessary FAA Approvals (STC's, etc.) are available for your aircraft before starting the installation.** The FAA Approved Model List (AML) is located at the back of this manual.
4. Read the entire Installation Instructions and resolve any issues you may have before starting the installation.
5. **THIS INSTALLATION WILL REQUIRE SOME PARTS UNIQUE TO YOUR AIRCRAFT THAT ARE NOT SUPPLIED IN THE KIT (including, but not limited to hoses and fittings).** Acquire all the parts necessary to install this instrument before starting the installation. Do not use aluminum fittings with the FXT-201 or FXT-231 transducer.
6. Check that the instrument make and model are correct before starting the installation (check the markings on the side of the instrument). A gravity feed system requires an FXT-231 flow transducer (marked "231" on top). A carbureted engine with a fuel return line requires an FFDM-I , which can be purchased from Electronics International, 12620 S.W. 231 PL, Hillsboro OR (503) 628-9113.
7. Before starting the installation make sure the unit will fit in the location you intend using. Refer to J.P.Instruments installation report 103, for the EGT-701, temperature indicator , STC SA 2586NM.
8. If this instrument is to replace an existing unit in the aircraft, it is the installer's responsibility to move or replace any existing instruments or components in accordance with FAA approved methods and procedures. The following Installation Instructions do not cover moving or the removal of any existing instruments or components.
9. Before connecting any hoses to the transducer, thoroughly clean them and insure they are free of any loose material. **Never pass high pressure air through or blow through the transducer, damage will occur.**
10. Remove the transducer cap plugs when ready to install hoses. Do not use aluminum fittings with the fuel flow transducer or Gauling may occur.
11. Note the direction of fuel flow marked on the transducer. Fuel must flow in this direction.
12. Mount the transducer with the three wires pointing up.
13. Note and record the K-factor engraved in the side of the transducer.

3.... Installing the Fuel Flow Transducer:

Mount the Fuel Flow Transducer using the appropriate drawing at the back of this manual.

Aircraft Configuration	Drawing #	Location	Page
1. All gravity Flow installations without fuel pump. Must use FXT-231	700923	Between Fuel tank and Carburetor.	8
2. All Fuel injected engines with vapor return lines to fuel tank , all Continental and certain Lycoming engines.	700922	Between throttle body and fuel flow divider.	9
3. All pump fed carbureted and Fuel injected engines without vapor return lines.	700921	Between engine driven pump and servo/throttle body or carburetor	10
4. Pressure Carbureted engines with vapor return lines	700923 700920	One transducer in Carb inlet line and one transducer in out let line	8, 11, 12

The instructions listed below must be followed when installing a Fuel Flow Transducer.

Note: If your engine is equipped with a fuel return line from the carburetor back to the fuel tank you will need to install two flow transducers... one in the feed line from the fuel pump to the carburetor and one in the return line from the carburetor back to the fuel tank. Also, a Fuel Flow Differential Module (Dwg. 700920) will need to be installed.

The transducer output port should be mounted lower or even with the carburetor inlet port (or fuel servo on a fuel injected engine). If this is not possible, a loop should be put in the fuel line between the Fuel Flow Transducer and the carburetor or fuel servo (see diagram below).

Do not remove the caps on the flow transducer until the fuel hoses are ready to be installed.

The flow of fuel through the transducer must follow the direction marked on the transducer.

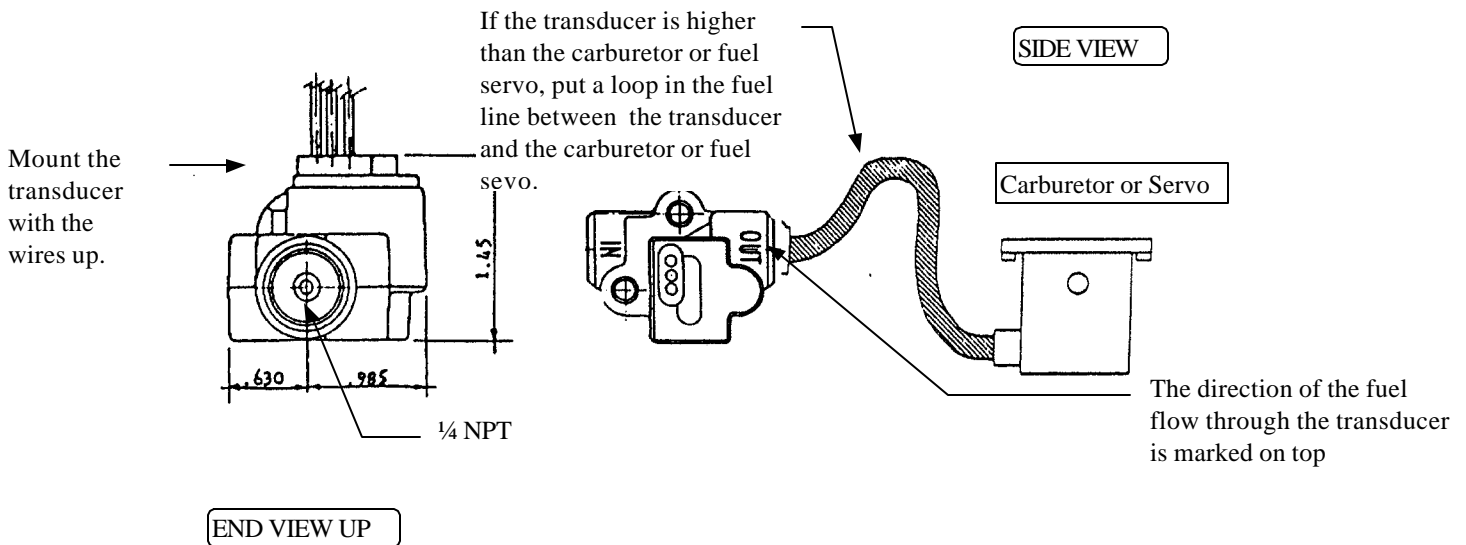

The flow transducer must be mounted so the wires exiting the transducer are pointing up. Before connecting any hoses, thoroughly clean them and insure they are free of any loose material. High air pressure may be used, **However, do not allow high air pressure to pass through the flow transducer.**

4.... Route the (Optional) External Warning Control Line:

The wire from pin 12 on the J-1 (D-SUB 25) Connector can be connected to an external warning light or buzzer. This wire grounds when the display flashing a warning is on. The current in this line must be limited to 2/10 of an amp maximum. Exceeding this limit will damage the unit. If this feature is not used leave this line open. Tie wrap this wire so it does not obstruct the freedom of travel controls.

5.... Install the Instrument in the Panel: (The following section is an excerpt from report #103 Installation Manual, STC 2586NM)

Locate a 2.25 diameter hole in the instrument panel, where you would like to mount the indicator per drawing 700124. A steel template supplied with the installation kit is used as a guide for drilling two button holes in the instrument panel. Align and **Mount** the Template into the instrument panel hole. First drilling a 0.125 hole. Remove the template and check the instrument alignment, if OK redrill with a 0.147 drill. The EGT-701(),with Fuel Flow option mounts in a standard 2.25" instrument hole. The instrument **configures itself automatically** for 4 to 9 cylinder, 14/28 volt aircraft. The instrument is 7.5" deep less connectors and is 2.6 square behind the panel. To prevent display damage it is essential that the mounting screws not penetrate the bezel more than .12 inches.

The indicator is FAA TSO approved, as a temperature indicator under TSO-C43b and must be installed in accordance with STC SA2586NM.

Mount the placard "Do Not Rely on Fuel Flow Instrument to Determine Fuel Levels in Tanks" on the aircraft instrument panel near the EGT-701(), with fuel flow option. If the aircraft is equipped with a primary fuel flow instrument, the following placard must be mounted on the aircraft instrument panel near the EGT-701(),with Fuel Flow option: **"Refer to Original Fuel Flow Instrumentation for Primary Information"**.

6.... Route the Fuel Flow Transducer Wires: (The following section is an excerpt from report #103 Installation Manual, STC 2586NM)

Route the thermocouple and fuel flow wires from the probes through the firewall using fireproof rubber grommets and flame retarding silicone. Use an existing hole if possible. Following the existing wiring harness and connect to the indicator marking each lead with the cylinder number. All wires must be routed **away from high temperature** areas (exhaust stacks, turbochargers, etc.). Secure Probe leads to a convenient location on the engine approximately 8 to 12 inches from the probe, being sure there is sufficient slack to absorb engine torque. It is essential in routing the probe and fuel flow transducer wires not be allowed to touch metal parts of the air-frame or engine since abrasion will destroy this wire. Connect wires in accordance with dwg 700744, page 12

7..... System Checkout: Check instrument operation as follows:

1. Turn the aircraft master switch on (engine off) and set the toggle switch to Fuel Flow . Tap the step switch until 0 GPH is displayed. Turn the boost pump on for a few seconds. The display should indicate 3 to 8 GPH.. A problem at this step could be caused by poor connections on the red or black power and ground leads.
2. Set the instrument toggle switch to "Fuel Flow" and check for a digital fuel flow reading of "00 GPH" indicates the fuel flow is too low to register. A reading of " ---GPH " dashes indicate no fuel flow transducer signals. A problem at this step could be caused by a poor connection or crossed flow transducer wires.
3. With the engine running, check the "FLOW" Display Mode to read properly. If there is a problem at this point Refer to EDM-700 Fuel Flow Option Supplement Rev C. Section 4 for troubleshooting information.
4. **After running the engine, check the fuel hoses, transducers and fittings for leaks.**

8... Specifications and Limitations

Model:

EGT-701(), with Fuel Flow option

Case Dimensions:

2.5" x 2.5" x 7.5" depth, 2 1/4" Bezel.

Weight:

Unit Only: 16 oz
Flow Transducer: 3 oz

Environmental:

Passed TSO C43c and DO-178a (software level 3)

Power Requirements:

10 to 35 Volts, 2 Amp.

Low Fuel Warning Display

The display message will blink anytime the programmed Low Fuel Reminder, Low Fuel Warning or the Time to Empty Limit are violated.

External Warning Control Line:

Grounds when any Warning display is on or blinking. Current should be limited to 2/10 amp.

Accuracy:

Flow: 2% or better in accordance with TSO C44a.

Resolution

Fuel Flow: 0.1 Gal. or 1 Lb. or .1 Ltr.
Fuel Remaining: 0.1 Gal. or 1 Lb. or .1 Ltr.
Fuel Used: 0.1 Gal. or 1 Lb. or .1 Ltr.
Time to Empty: 10 minute

Max Displayed Range (Unit Only):

Fuel Flow: 199.9 Gals. or 162.0 or Gal/Hr or 1199 Lbs/Hr or 749 Ltr/Hr.
Fuel Remaining: 999 Gals. or 811 or Gals. or 1999 Lbs. or 1999 Ltrs.
Fuel Used: 999 Gals. or 811 or Gals. or 1999 Lbs. or 1999 Ltrs.
Time to Empty: 19 hours 59 minutes

J.P.Instruments Fuel Flow Installation Manual **for EGT-701 with Fuel Flow Option**

Report # 503
Page 7 of 14
Rev B : Date 03/14/97

9... Pilot Programmable Modes: (excerpt from STC 2586NM)
See JPI Installation Manual For EGT-701, No 103 Page 8 for more information.

RS232/422 Input Ports (EGT-701()),with Fuel Flow option Only!:

Single Line Receive Method:	RS-232C, RS423, or 5 Volt Serial.
Dual Line Receive Method:	RS-422 or RS-485.
Protocol:	1 Start bit, 8 Data bits, 1 Stop bit.
Baud Rate:	L 1 = 9600, L 2 = 1200
Format:	Moving Map Output: L 1 = King KIN-88, L 2 = Northstar

RS232 Output Port

Transmit Method:	RS-232 Single Line.
Protocol:	1 Start bit, 8 Data bits, 1 Stop bit.
Baud Rate:	9600
Transmit Format:	King KIN-88.

Fuel Flow Transducer, Standard (FXT-201)

Range:	0.6 to 60 GPH
Linearity:	%1 (8 to 60 GPH)
K Factor	Approx. 29,000
Pressure Drop:	1.2 PSI at 30 GPH 4.8 PSI at 60 GPH
Working Press:	200 PSI
Min. Burst Press:	2000 PSI
Temp. Range:	-65°C to 125°C
Fuel Ports:	1/4" Female NPT

Fuel Flow Transducer, Gravity Only (FXT-231):

Range:	3 to 90 GPH
Linearity:	%1 (8 to 60 GPH)
K Factor:	Approx. 19500
Pressure Drop:	.31 PSI at 30 GPH 2.8 PSI at 90 GPH
Working Press:	200 PSI
Min. Burst Press:	2000 PSI
Temp. Range:	-65°C to 125°C
Fuel Ports:	1/4" Female NPT

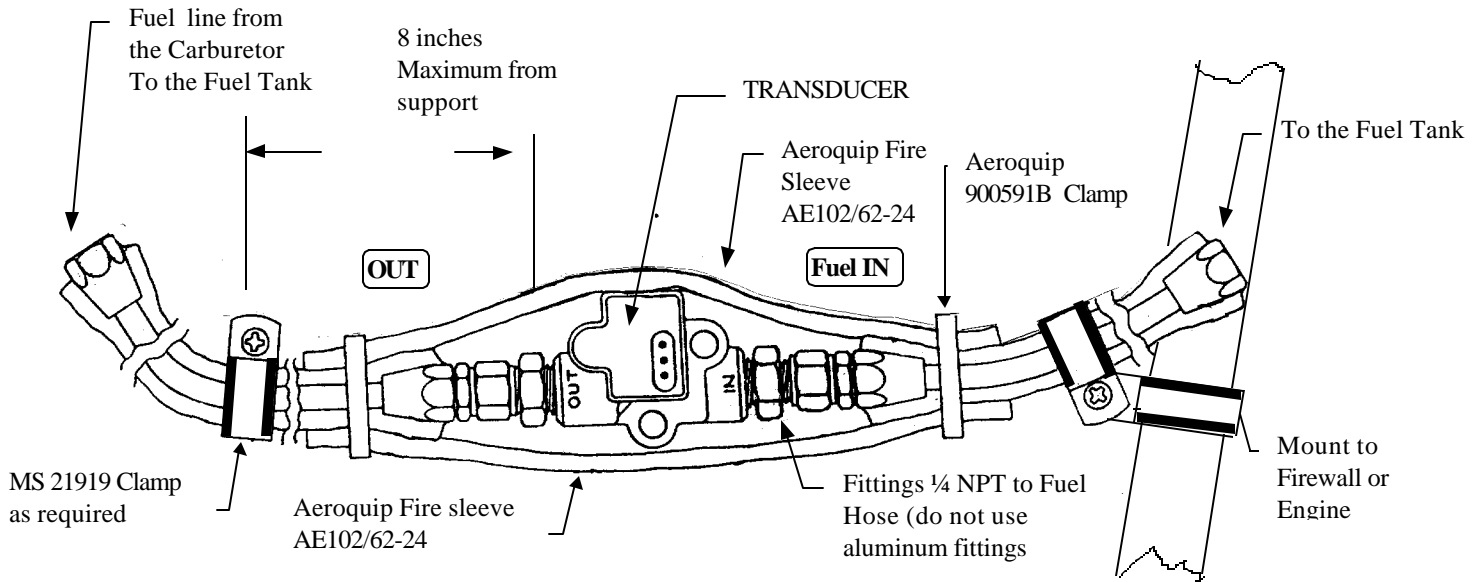

Mounting Procedure:

1. **Find a convenient** location within 8" of a hose support or fitting and away from **any** hot exhaust pipes to suspend the Fuel Flow Transducer. The hose support or fitting may be on the input or output line of the Flow Transducer.
2. Remove the fuel hose which goes from the Carburetor to the Fuel Tank.
3. Purchase two new hoses, one from the Carburetor to the Fuel Flow Transducer and the other from the Fuel Flow Transducer to the Fuel Tank. **There must be flexible hose in and out of the Transducer.** The hoses must meet TSO-C53a Type C or D FAA specification. **The new hoses must be the same diameter as the current hose in the aircraft.**
4. Mount the Fuel Flow Transducer in the fuel supply line and in the return line for pressure carburetors. **The Flow Transducer must be wrapped with Fire Sleeving.** Place a small hole in the fire sleeve and pass the transducer wires through it. Seal with High temperature Silicone RTV sealant.
5. Before connecting fuel hose to the carburetor , verify that the boost pump delivers at least 125% of takeoff fuel consumption at minimum fuel pressure as marked on fuel pressure gage.

J.P.INSTRUMENTS			
PO Box 7033			
Huntington Beach CA 92646			
Title : Installation of a Fuel Flow Transducer in the fuel supply or return line from the carburetor to the fuel tank			
Drawing No.		700923	
Date	Drawn/	Approved	Rev NC
02/14/97			

Mounting Procedure:

1. Find a convenient location between the Throttle Body and the Flow Divider and away from any hot exhaust pipes to suspend the Fuel Flow Transducer.
2. Remove the fuel hose which goes from the Throttle Body to the Flow Divider.
3. Purchase two new hoses, one from the Fuel Servo to the Fuel Flow Transducer and the other from the Fuel Flow Transducer to the Flow Divider. **There must be flexible hose in and out of the Fuel Transducer.** The hoses must meet TSO-C53a Type C or D FAA specification. The new hoses **must be the same size as the current hose in the aircraft.** A source of fittings and fabricated hoses is:
4. Mount the Fuel Flow Transducer in the fuel line. **The Flow Transducer must be wrapped with Fire Sleeving.** Place a small hole in the fire sleeve and pass the transducer wires through it. Seal with High temperature Silicone RT² sealant.
5. Secure at either end of the transducer to any convenient point on the engine with MS21919 clamps or equivalent.
6. For Continental fuel injected engines adjust the fuel pressure to account for the pressure drop across the transducer per Continental Service Bulletin M89-10

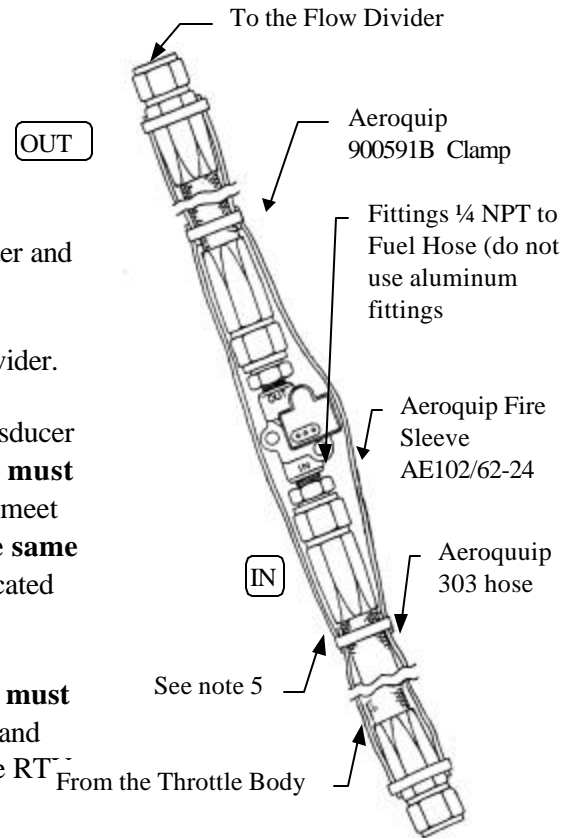

J.P.INSTRUMENTS			
PO Box 7033			
Huntington Beach CA 92646			
Title Installation of the Fuel Flow Transducer in the fuel line between the Throttle Body and the Flow Divider. Only applicable for Continental Fuel Injected Engines			
Drawing No. 700922			
Date 02/14/97	Drawn/	Approved	Rev NC

J.P.Instruments Fuel Flow Installation Manual

for EGT-701 with Fuel Flow Option

Report # 503
 Page 10 of 14
 Rev B : Date 03/14/97

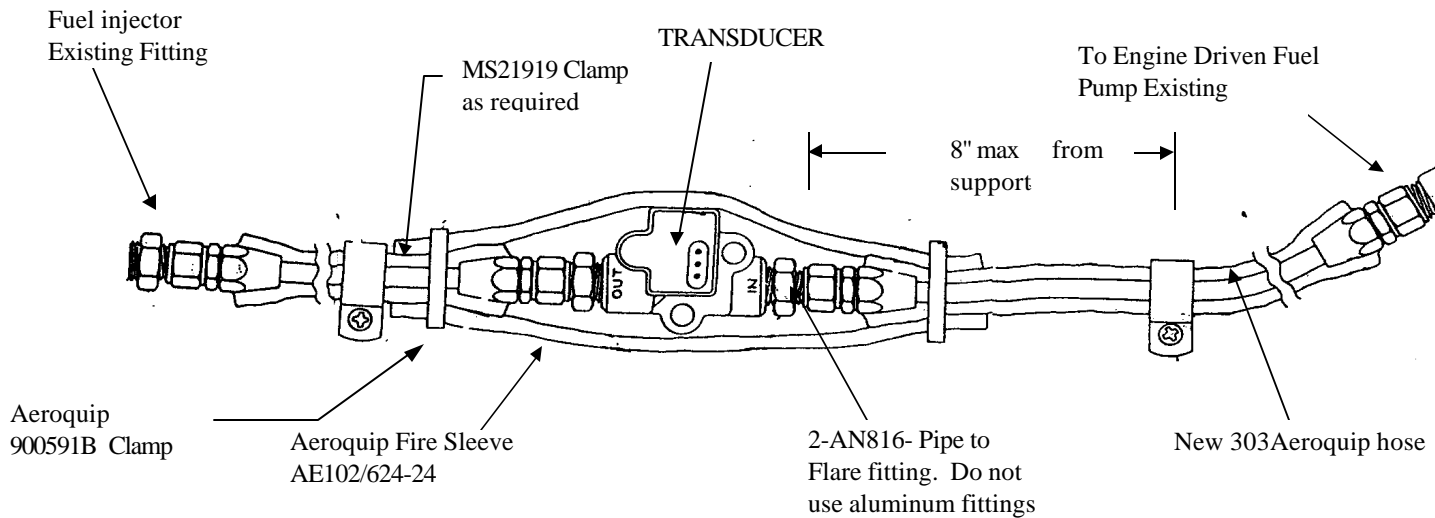

Mounting Procedure:

1. Find a convenient location within 8" of a hose support or fitting and away from any hot exhaust pipes to suspend the Fuel Flow Transducer. The hose support or fitting may be on the input or output line of the Flow Transducer.
2. Remove the fuel hose which goes from the Fuel Pump to the Carburetor (or Fuel Servo).
3. Purchase two new hoses, one from the fuel pump (or the Fuel Filter) to the Fuel Flow Transducer and the other from the Fuel Flow Transducer to the carburetor (or fuel servo). **There must be flexible hose in and out of the Transducer.** The hoses must meet TSO-C53a Type C or D FAA specification. **The new hoses must be the same size as the current hose in the aircraft.**
4. Mount the Fuel Flow Transducer in the fuel line. **You must use the FXT-231 Fuel Flow Transducer on a gravity feed system.** The FXT-201 Transducer is marked "Model 231" on the top of the transducer. **The Flow Transducer must be wrapped with Fire Slewing.** Place a small hole in the fire sleeve and pass the transducer wires through it. Seal with High temperature Silicone RTV sealant.
5. Before connecting fuel hose to the carburetor , verify that the boost pump delivers at least 125% of takeoff fuel consumption at minimum fuel pressure as marked on fuel pressure gage.

J.P.INSTRUMENTS			
PO Box 7033			
Huntington Beach CA 92646			
Title : Installation of a Fuel Flow Transducer in the fuel line from the fuel pump to the carburetor or fuel servo.			
Drawing No. 700921			
Date	Drawn	Approved	Rev NC
02/14/97			

PRODUCTION RELEASE 9 / 96

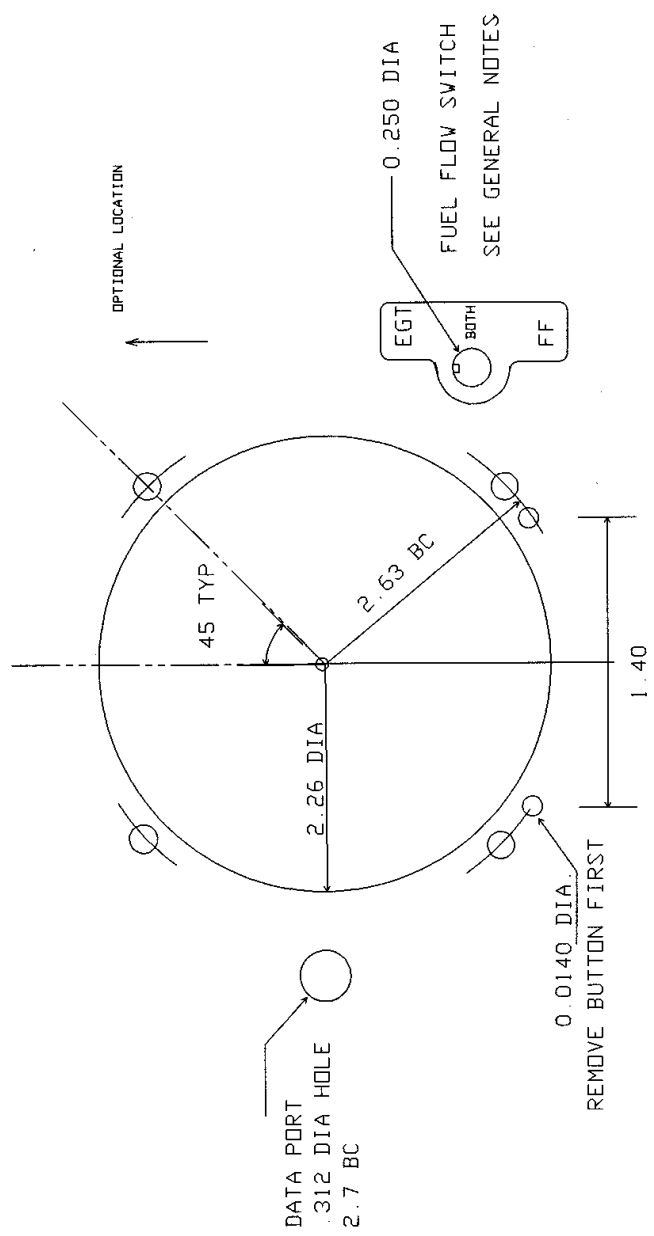

GENERAL NOTES:

- 1) MOUNT SWITCH CLOSE TO THE RIGHT OF INSTRUMENT IN LOWER RIGHT.
AS SHOWN
- 2) LOCATE DATA PORT NEAR INSTRUMENT ON LEFT SIDE.

This drawing contains
 proprietary information
 of J.P. Instruments
 © Copyright 1994

FIG-1

J. P. INSTRUMENTS SANTA ANA CA 92704	
TITLE:	TEMPLATE 2.25
PART NO.	700124
REV	NC
DATE:	5/96
APP	
	SHEET 1 OF 1

PRODUCTION RELEASE 3 00

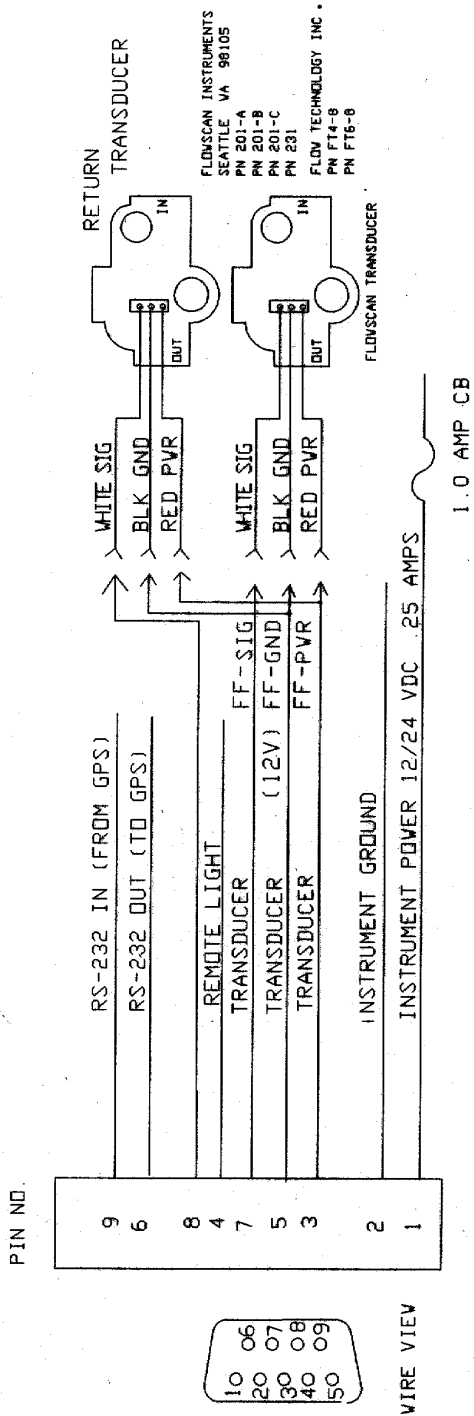

GENERAL NOTES

- 1 A COMPLETE THROUGH FAMILIARIZATION AND UNDERSTANDING OF THE SYSTEM IS NECESSARY BEFORE COMMENCING THE INSTALLATION. ALL WORK MUST CONFORM TO AC 43.13-1A CH.11, SEC 2.3.7 REQUIREMENTS.
- 2 FS-450 CAN BE CONNECTED TO ANY PREVIOUSLY INSTALLED DIGITAL FLOW MEASURING DEVICE LIKE A FLOWSCAN TRANSDUCER
- 3 ROUTE WIRES ALONG EXISTING WIRE BUNDLES

J.P. INSTRUMENTS
 SANTA ANA CA 92704

TITLE: FUEL FLOW WIRING	REV NC
PART NO: 450508	SHEET 1 OF 1
DATE: 3 /00 APP	

This drawing contains
 proprietary information
 of J.P. Instruments
 © Copyright 2000

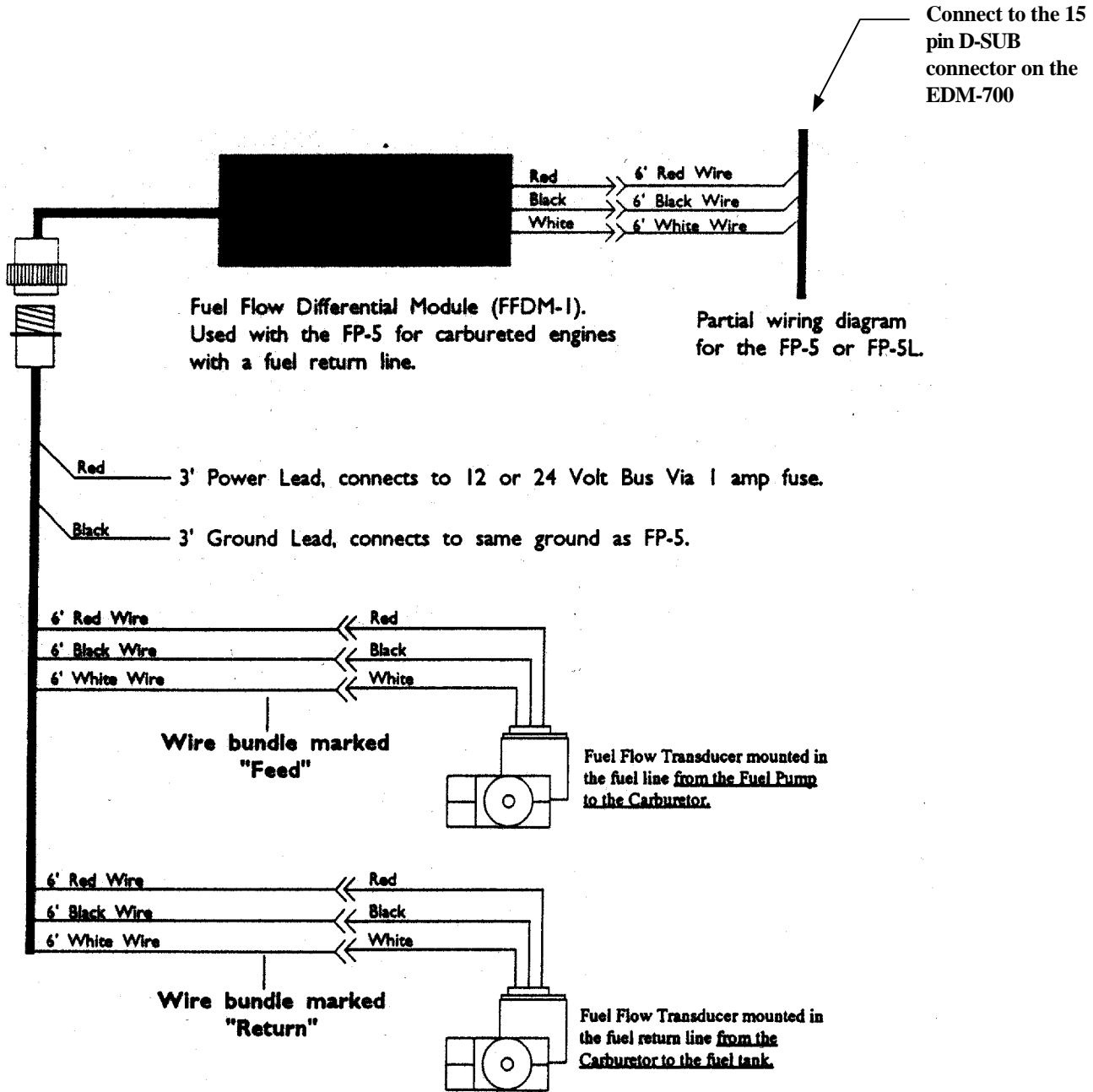

J.P.INSTRUMENTS				
PO Box 7033				
Huntington Beach CA 92646				
Title: FFDM-1 Interconnect Wiring Diagram				
Drawing No. 700920				
Date	Drawn	Approved	Sheet	Rev
02/14/97			1 of 2	NC

10.. Installing the *Electronic International* Fuel Flow Differential Module (FFDM-I):

If your engine is equipped with a fuel return line from the carburetor back to the fuel tank, install the FFDM-1 in the aircraft as outlined below (see sheet one). Otherwise, omit this step.

- a) Connect the connector to the FFDM-I.
- b) Install the FFDM-1 under the instrument panel using two tie wraps on each end of the module to support it to a wire bundle or bracket.
- c) Route and connect the 3' red power lead to the 12 or 24 volt bus via a 1 amp fuse.
- d) Route and connect the 3' black ground lead to the same ground used for the EGT-701(),with Fuel Flow option.
- e) Route and connect the 6' red, black and white leads marked "Feed" to the flow transducer installed in the fuel line from the fuel pump to the carburetor.
- f) Route and connect the 6' red, black and white leads marked "Return" to the flow transducer installed in the return fuel line from the carburetor to the fuel tank.
- g) Connect the red, black and white leads to the same color 6' leads from the EGT-701(),with Fuel Flow option.

Any excess wires can be rolled up and tie wrapped under the instrument panel. **Tie wrap these wires so they do not obstruct the freedom of travel of any controls.**

J.P.INSTRUMENTS				
PO Box 7033				
Huntington Beach CA 92646				
Title: FFDM-1 Interconnect Wiring Diagram				
Drawing No. 700920				
Date	Drawn	Approved	Sheet	Rev
02/14/97			2 of 2	NC